

					Name	Date	Title	
				Created By				
				Checked By				
				Scale				
				Bread Tray			Drawing Number	Issue
				(c) 2006 Chris Baylor Licensed to About.com, Inc.				
				http://woodworking.about.com				
No	Change	Date	Init					

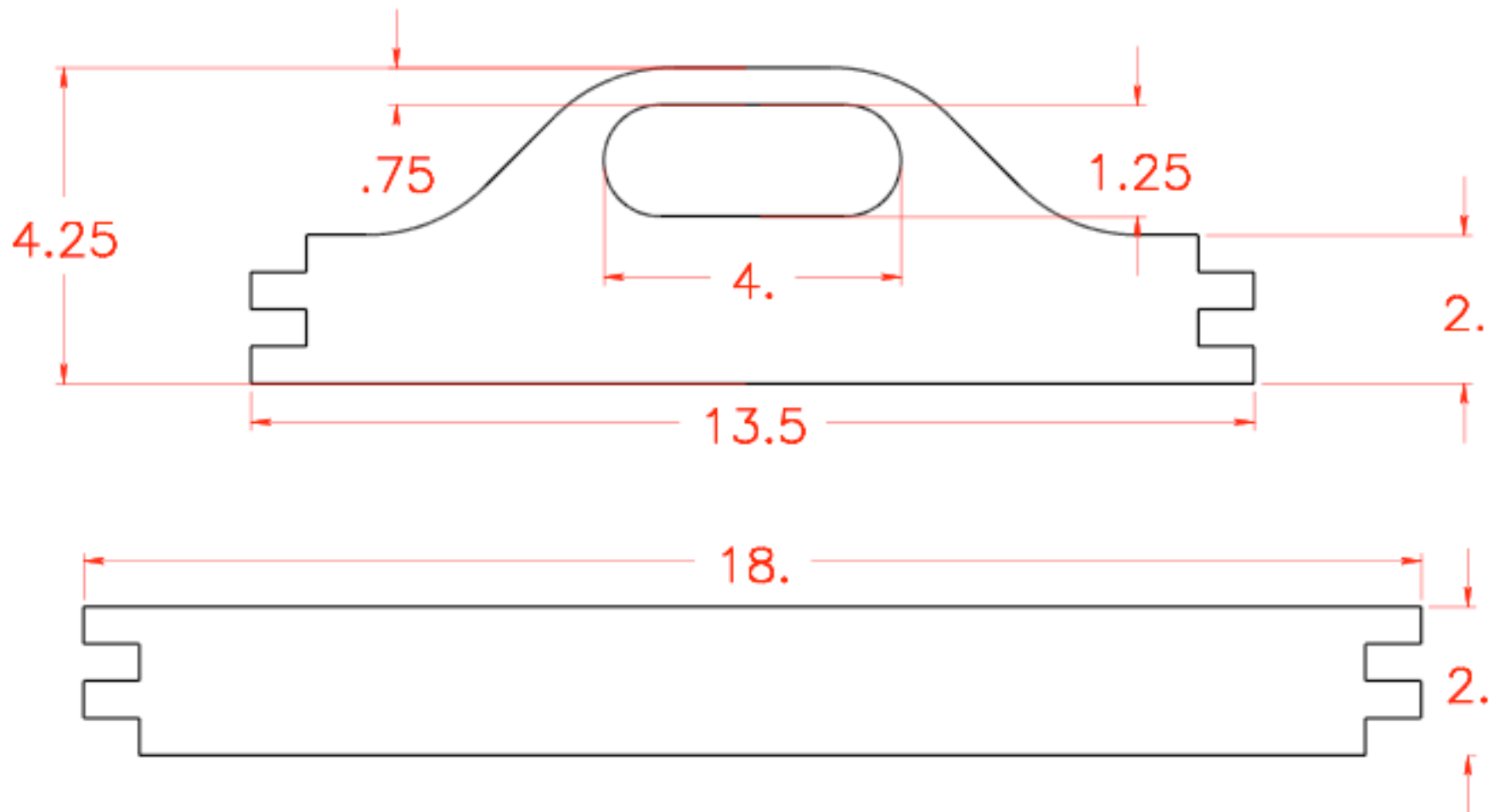

No	Change	Date	Init	Name	Date	Title	
				Created By			
				Checked By			
				Scale			
				Bread Tray		Drawing Number	Issue
				(c) 2008 Chris Baylor Licensed to About.com, Inc.			
				http://woodworking.about.com			

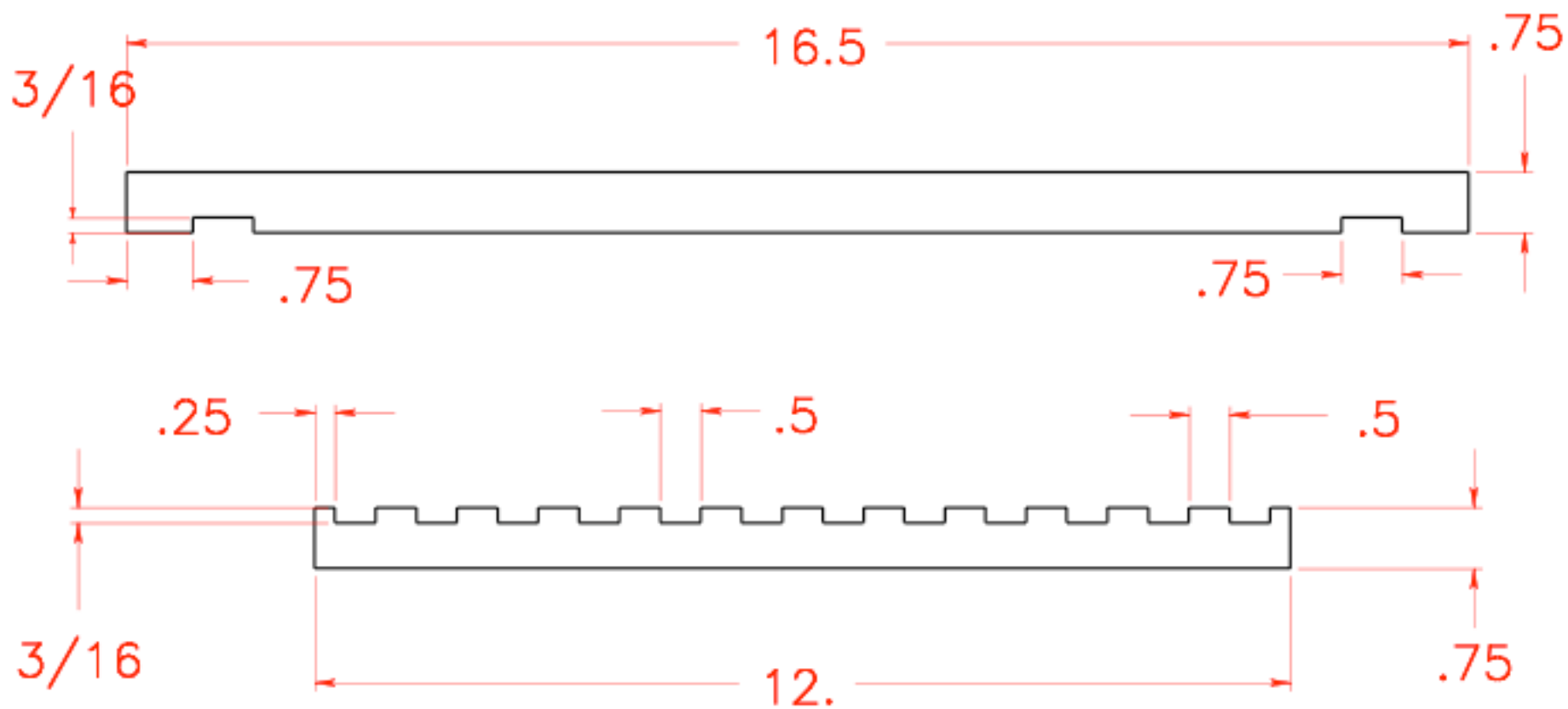

					Name	Date	Title	
				Created By				
				Checked By				
				Scale				
				Bread Tray			Drawing Number	Issue
				(c) 2008 Chris Baylor Licensed to About.com, Inc.				
				http://woodworking.about.com				
No	Change	Date	Init					

Bill of Materials

Item	Title	Qty.	Stock	Dimensions	Details
A	Ends	2	1x6	13.5" x 4.25"	2 pieces of 1x6 stock, ripped to 4.25" width.
B	Sides	2	1x6	18" x 2"	1 piece of 1x6 stock at 18" long ripped into two 2" wide pieces.
C	Slats	12	1x6	16.5" x .5"	Slats ripped from 1x6 to 1/2" widths
D	Struts	4	1x6	12" x .75"	Struts ripped from 1x6 to 3/4" widths